

BIOHYDROGEN II

**An Approach to Environmentally
Acceptable Technology**

Edited by

Jun Miyake,

Tissue Engineering Research Center,
AIST/METI, Tsukuba, Ibaraki, Japan

Tadashi Matsunaga,

Tokyo University of Agriculture and Technology,
Koganei, Tokyo, Japan

Anthony San Pietro,

Indiana University, Bloomington, Indiana, USA



2001

PERGAMON

An Imprint of Elsevier Science

Amsterdam - London - New York - Oxford - Paris - Shannon - Tokyo

A SCHEME FOR DEVELOPING THE YIELD OF HYDROGEN BY FERMENTATION

S. Tanisho

Department of Environmental Sciences
Yokohama National University
Hodogaya-ku, Yokohama 240-8501, JAPAN
E-mail: tanisho@chemeng.bsk.ynu.ac.jp

ABSTRACT

It is necessary to understand the yield of hydrogen from various substrates in order to produce hydrogen efficiently by fermentation. The yield differs depending on the bacteria utilized. If we use strict anaerobic bacteria, for example, we expect a maximum yield of 4 mol H₂ from 1 mol glucose by directing the bacteria's metabolism to acetate formation. In the case of facultative anaerobic bacteria, we may expect a maximum 10 mol H₂ from 1 mol glucose by using the TCA cycle and re-oxidizing the FADH₂ generated in the electron transport system. In this presentation, these possibilities are discussed from the point of reduction-oxidation reactions.

1. CONVERSION EFFICIENCY OF ENERGY PRODUCTION BY HYDROGEN FERMENTATION

There are several ways to produce energy by fermentation, such as methane fermentation, ethanol fermentation and hydrogen fermentation. Of these, methane fermentation is rather organic waste treatment than energy production, while ethanol fermentation is of practical importance under certain conditions as demonstration in Brazil. Hydrogen fermentation is still not in practical use because the energy conversion efficiency from substrates is fairly low (Table 1), and also is not estimated from a suitable point of view for utilization.

TABLE 1
IDEAL YIELD AND ENERGY RECOVERY FROM GLUCOSE

Material	yield	heating value [kJ/mol]	recovery [%]
Methane	3	2,646	94
Ethanol	2	1,645*	58
Hydrogen	2	572	20
	4	1,144	41
	6	1,716	61
	8	2,288	81
	10	2,860	102

*; estimated the distillation energy at 40%
of the product.

Although, ethanol fermentation (equation 1) is known to have high conversion efficiency (97% estimated from the ideal enthalpy recovery), the real efficiency falls to around 50% if we consider the distillation energy (Table 1). This is the non improvable efficiency.



In contrast, since hydrogen fermentation (Eq. 2) does not require a distillation step, the real efficiency will ideally be comparable to ethanol fermentation. Moreover, it may become more effective than ethanol fermentation if we utilize the hydrogen in a fuel of fuel cell.

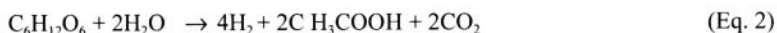

As stated above, we can expect a higher energy conversion efficiency for hydrogen fermentation by improving the yield of hydrogen. In this paper, I will present a scheme for increasing the yield of hydrogen.

2. PATHWAY OF HYDROGEN PRODUCTION

2.1. Three Pathways of Hydrogen Production

Many pathways have been suggested for hydrogen production by bacteria. Among these, three representative pathways are shown in Figure 1.

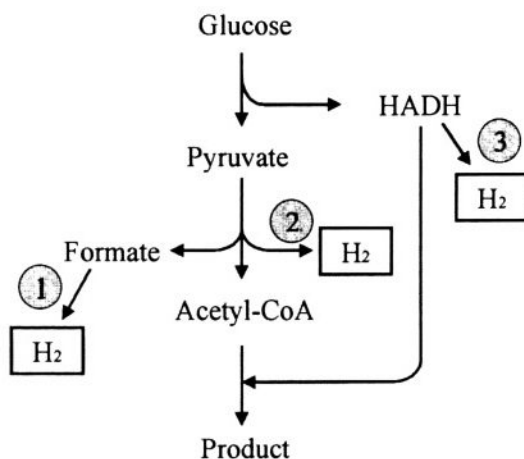
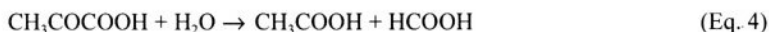

Figure 1: Three ways of the hydrogen pathway.

One is the formate pathway characteristic of the mixed acid fermentation by bacteria such as *Escherichia coli*. The pathway was proposed from stoichiometric considerations, such as the molar amount of formate at pH around 7 is equal to the molar amount of CO₂ and H₂ at pH below 6.



This pathway is closely related with acetate production, therefore, it may become an important pathway for the improvement of hydrogen yield through acetate fermentation.



The second is the direct production pathway characteristic of the acetone-butanol fermentation by bacteria such as *Clostridium butyricum*. In this pathway, hydrogen is produced directly without formate production. This pathway, however, may be unified with NADH pathway, because the mass balance of NADH (Nicotinamide Adenine Dinucleotide, reduced form) shows the same result with NADH pathway.

The third pathway is the NADH pathway which was proposed from a concept that *Clostridium butyricum* re-oxidizes residual NADH to NAD⁺ by producing H₂ during butyrate fermentation.



In the butyrate fermentation, 2 mol of H₂ and 2 mol of NADH are produced ideally from 1 mol of glucose. Reoxidation of NADH produces H₂.

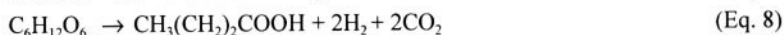

For example, *C. butyricum* produced 235 mmol of H_2 from 100 mmol of glucose. In this case, 76 mmol of butyrate and 42 mmol of acetate were also produced from 100 mmol of glucose. The volume of evolved hydrogen was in good agreement with the calculated volume from the mass balance of analysis. Moreover, the hydrogen yield (2.35) from glucose was the largest ever reported. This is a known example for increased yield by increasing acetate or residual NADH and suggests the direction for future yield improvement.

2.2. Mechanism of Hydrogen Production Through NADH Pathway and Redox Potential

For hydrogen production through the NADH pathway, the membrane-bound hydrogenase accepts electrons from NADH inside the cell and transfers them to protons outside the cell to evolve molecular hydrogen (Fig. 2). This mechanism is feasible from electrochemical considerations as follows:

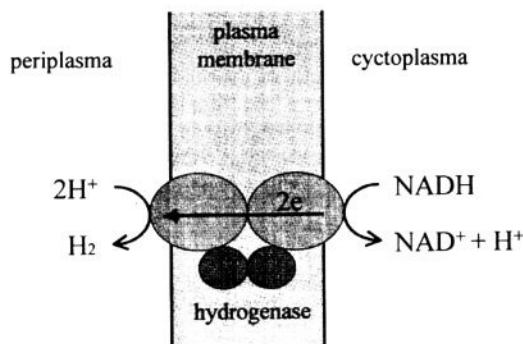
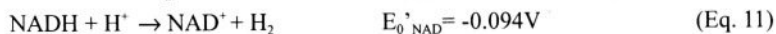
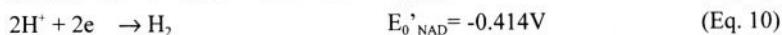

Figure 2: Mechanism of hydrogen production of NADH pathway.

The reactions producing H_2 from NADH are expressed as two electrochemical reaction equations as follows:



Redox potentials of these reactions are expressed by functions of pH as follows,

NAD:

$$\begin{aligned} E &= E_0 + (RT/2F) \ln([\text{NAD}^+][\text{H}^+]/[\text{NADH}]) \\ &= E_0 + (2.303RT/2F)(\text{pH}) + (2.303RT/2F) \log([\text{NAD}^+]/[\text{NADH}]) \\ &= -0.113 - 0.0296 \text{pH} + 0.0296 \log([\text{NAD}^+]/[\text{NADH}]) \end{aligned} \quad (\text{Eq. 12})$$

H₂:

$$E = (RT/2F) \ln([H^+]^2/p_{H_2}) = - 0.0592 \text{ pH} - 0.0296 \log(p_{H_2}) \quad (\text{Eq. 13})$$

These relations are shown in Figure 3.

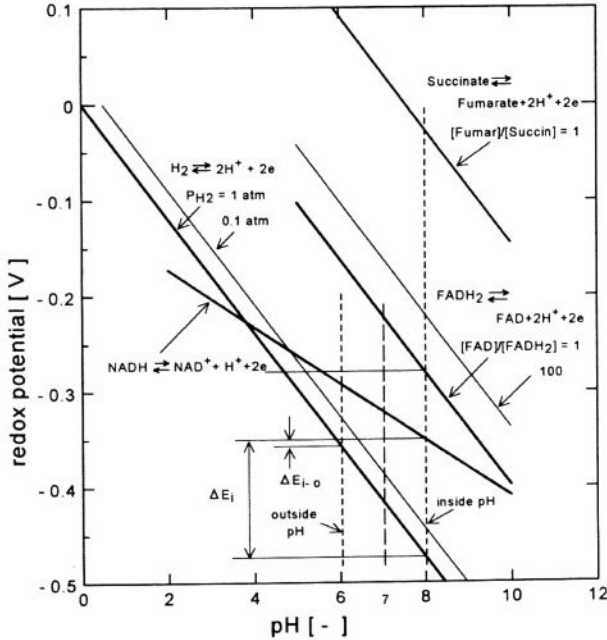

Figure 3: Culture pH vs. redox potential.

If H₂ is produced inside the cell, $\Delta E_0'$ is negative the Gibbs's free energy change, $\Delta G_0' = -nF\Delta E_0'$, becomes positive, 23.9 kJ/mol at pH 8 (well known inside pH of *Escherichia coli*), and the equilibrium constant, $K' = [NAD^+][H_2]/[NADH]$, becomes 6.5×10^{-5} . This means that if H₂ is produced inside the cell, only 10⁻⁴ atm of partial H₂ pressure will stop H₂ production. But, if H₂ is produced outside the cell at pH 6 and NADH is oxidized inside the cell at pH 8, $\Delta E_0'$ becomes nearly 0 and therefore H₂ production is possible even at approx. 1 atm of partial pressure of H₂. In fact, bacteria produced H₂ continuously under a partial pressure 0.6 atm.

3. ANAEROBIC OR FACULTATIVE ANAEROBIC BACTERIA

There are two kinds of hydrogen producing bacteria, one is facultative anaerobic bacteria and facultative anaerobic bacteria. We have to evaluate on the metabolic pathways of these bacteria to determine for which bacteria an improved hydrogen yield is possible.

3.1. Glycolysis

There are two pathways degrading glucose to pyruvate; i.e., the Embden-Meyerhof(EM) pathway and the Entner-Doudoroff(ED) pathway. By the EM pathway, 2 mol of NADH are produced while 1 mol each of NADH and NADPH (Nicotinamide Adenine Dinucleotide Phosphate, reduced form) is produced by the ED pathway as follows.

EM pathway:



ED pathway:



Utilized pathway differs by bacterium, though NADP as well as NAD is the coenzyme participating in the reduction-oxidation reaction of organic substance and also has the structural resemblance. It is, therefore, not too much to say that the glycolytic pathway of the bacteria producing hydrogen by NADH pathway is the EM pathway (Figure 4).

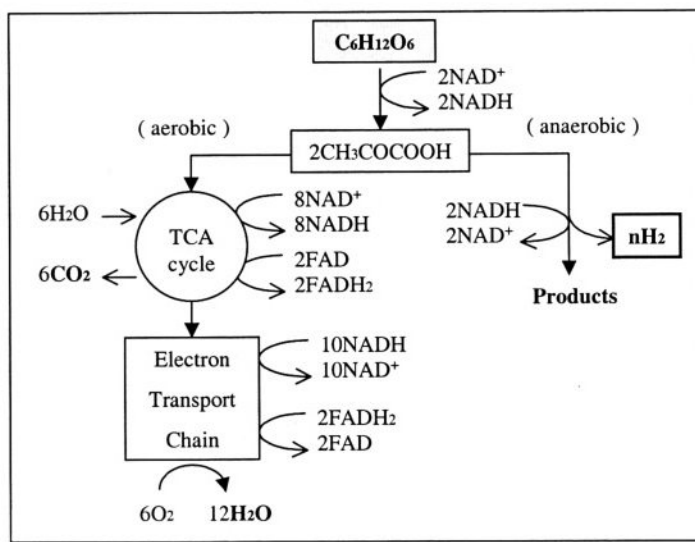

Figure 4: Aerobic and anaerobic degradation of glucose.

3.2. Metabolic Pathway of Anaerobic Bacteria

As seen in the above, NAD works as the coenzyme in glucose metabolism, therefore, NADH has to be re-oxidized to NAD^+ to support continued glucose oxidation. Anaerobic bacteria such as Clostridia re-oxidizes NADH by producing organic acids like lactate, acetate and butyrate as well as alcohols like ethanol, butanol and butanediol, from pyruvate. Many bacteria have multiple metabolic pathways, and change the pathway in accordance with metabolite availability and/or pH in the culture liquid. Therefore, in general, it is very

difficult to restrict metabolism to a single pathway not only by fermentation but also by genetic.

3.3. Metabolic Pathway of Facultative Anaerobic Bacteria and the Amount of NADH Produced Under Aerobic Conditions

Facultative anaerobic bacteria such as *Enterobacteriaceae* and *Bacillus* species produce organic acids and alcohols from pyruvate and NADH under anaerobic conditions in a way similar to anaerobic bacteria. However, the facultative anaerobes possess the pathways for aerobic metabolism, such as the TCA cycle and electron transport system (even under anaerobic condition), and quickly respond to the presence of oxygen to oxidize NADH via the by electron transport system. NADH are also produced in the TCA cycle as seen in Figure 4. In the presence of oxygen, hydrogen production stops.



ATP is produced effectively by the electron transport system under aerobic conditions.

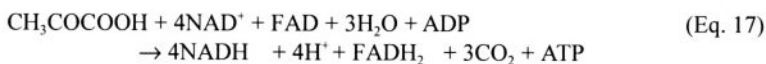

Therefore, if we can utilize the NADH produced in the TCA cycle as a source of hydrogen production, the yield should increase. Moreover, metabolites from glucose should become only H_2 and CO_2 , the treatment of waste water, therefore, will be lightened.

4. HOW TO MODIFY THE TCA CYCLE

Why does the TCA cycle works only under aerobic conditions and not under anaerobic conditions. We need to utilize the TCA cycle as a NADH supplier and to increase H_2 yield.

4.1. Gibbs's Free Energy Change of TCA Cycle

The TCA cycle starts from citrate synthesis by acetyl-CoA and oxaloacetate as seen in Figure 5. This reaction, however, has a negative free energy change ($\Delta G_0' = -32.3$ kJ); therefore, oxaloacetate must react very quickly with acetyl-CoA and be kept nearly 0 concentration normally.

Detecting the free energy change of the cycle after citrate to succinate synthesis, $\Delta G_0'$ of the reactions are all 0 or very negative values, therefore, it must easily proceed to succinate synthesis. However, $\Delta G_0'$ of reactions from succinate to fumarate and from malate to oxaloacetate incline extremely to positive value, i.e., +36.0 kJ and +29.7 kJ, respectively. Since the equilibrium constant for these reactions becomes very small, such as 4.90×10^{-7} and 6.22×10^{-6} , respectively, these reactions therefore easily stop running by a slight amount of products. These reactions run with NAD or FAD (Flavin Adenine Dinucleotide) shown as follows:



TABLE 2
REDOX POTENTIAL

Redox compound	E_0' [mV]
O_2/H_2O	818
NO_3^-/NO_2^-	433
Ubiquinon	113
Fumarate/succinate	33
Oxaloacetate/malate	-172
FAD/FADH ₂	-220
NAD/NADH	-320
H^+/H_2	-414

5. ELECTRON TRANSPORT CHAIN AND INHIBITION

Electrons of FADH₂ and NADH are transported through the Electron transport chain to oxygen. Although aerobic or facultative anaerobic bacteria have the electron transport chain, but different microorganisms in general have different enzyme systems. In the mitochondrial electron transport system as shown in Figure 6, FADH₂ transports electrons at a different transport site with NADH, since FAD has a higher redox potential than NAD.

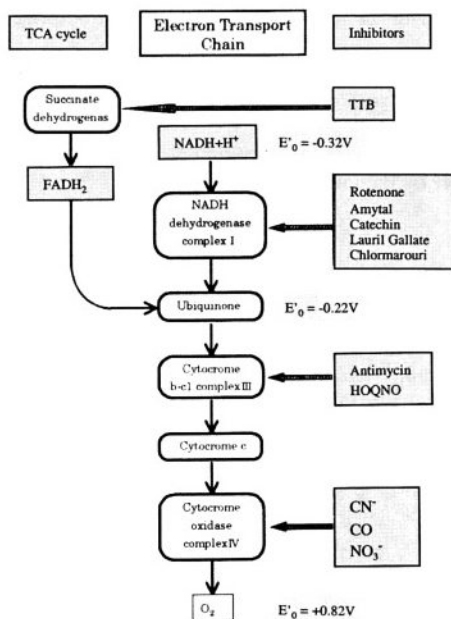

Figure 6: Electron transport chain and inhibitors.

Reminding that the concentration of oxaloacetate must be kept nearly 0 for the synthesis of citrate, malate-to-oxaloacetate reaction may run perpetually even if the concentration ratio $[NADH]/[NAD^*]$ is approximately 1 at anaerobic condition.

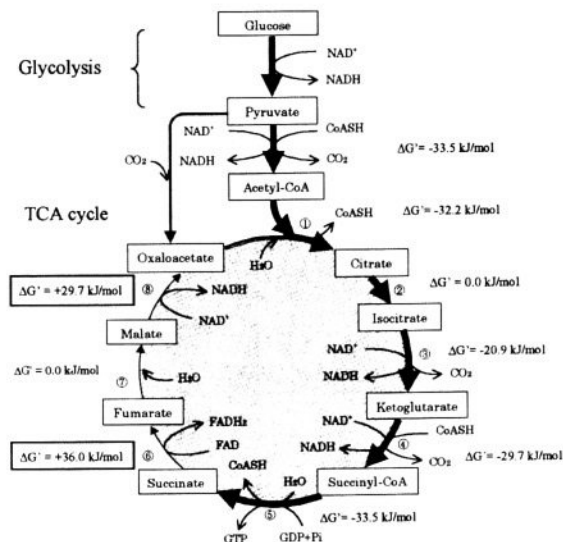

Figure 5: TCA cycle with Gibbs's free energy.

4.2. Redox Potential of FAD

In contrast to malate-to-oxaloacetate reaction, succinate-to-fumarate reaction is the reaction which FAD takes part in, and not only the equilibrium constant is very small but also the standard redox potentials of Fumarate/Succinate and $FAD/FADH_2$ are very high as seen in Table 2 and Figure 3. Consequently, if the concentration of $FADH_2$ becomes a little high by accumulation, concentration of fumarate becomes unsuitably small to keep the TCA cycle, for example, the concentration ratio of $[Fumarate]/[Succinate]$ becomes approximately 10^{-7} at $[FAD]/[FADH_2] \cong 1$. Therefore, $FADH_2$ must be reoxidized immediately and the concentration ratio of $[FAD]/[FADH_2]$ must be kept extremely high. Living organisms seem to solve this problem by using very high redox potential substance, i.e. oxygen, as the electron acceptor of $FADH_2$. In other words, the concentration ratio $[FAD]/[FADH_2]$ must be the switch of revolution of the TCA cycle.

From the above consideration, it has become clear that the oxidation of $FADH_2$ the most important problem to keep the TCA cycle.

This is a very lucky fact for us, because if we can oxidize FADH_2 by oxygen and separately NADH by H_2 production, then TCA cycle must run continuously. Such condition, we may realize by inhibiting the NADH active site of the electron transport chain under aerobic condition and culture pH lower than 6.

The over all reaction equation will be like follows, and we may expect a hydrogen yield of 10.

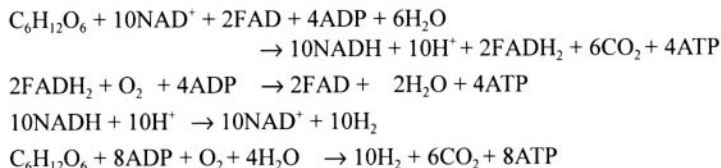

6. RESULTS OF THOUGHT EXPERIMENT

Then what will happen if NADH dehydrogenase complex (NADH active site) is inhibited and TCA cycle is still running. We can guess probable results by thought experiment as follows:

- 1) Because of higher ATP productivity, glucose consumption rate will be slow.
- 2) Because of higher ATP productivity, cell mass yield will be large.
- 3) Gas producing rate will increase owing to higher H_2 and CO_2 productivity.
- 4) CO_2 yield from glucose becomes larger.
- 5) H_2 yield from glucose will be larger, if NADH dehydrogenase do not concern H_2 production.
- 6) Volume ratio of H_2 to CO_2 will change in the produced gas.
- 7) Amount of liquid products will decrease in comparison with the amount of glucose consumption.

From the above results, we can prepare real experiments and judge whether the Improvement of hydrogen yield is possible by the inhibition or not.

7. CONCLUSION

A scheme improving hydrogen yield was proposed for the hydrogen production by fermentation and the improvement using facultative anaerobic bacteria is shown to be expectable to get the maximum yield. But actual experiments are still under preparation. Although we have to wait the decision of feasibility in future experiments, it is need to pay efforts to find strains lacking the NADH dehydrogenase complex in the wild or mutant strains.